

# ENHANCED WIRELESS CHANNEL STATE ESTIMATION THROUGH DEEP LEARNING FOR 6G COMMUNICATION

Dr. K. Amit Bindaj  
HOD, ECE  
SBIT, KHAMMAM  
Email: [karpurapu.gavasj@gmail.com](mailto:karpurapu.gavasj@gmail.com)

Mr. T. Gangadhar  
Asst.professor, ECE  
SBIT, KHAMMAM  
Email: [Gangadhar4vlsi@gmail.com](mailto:Gangadhar4vlsi@gmail.com)

Mr Ch. Gopala Rao  
Asst.professor, ECE  
SBIT, KHAMMAM  
Email: [chintala.gopal4@gmail.com](mailto:chintala.gopal4@gmail.com)

**Abstract-** There is a pressing need to find solutions to the problems caused by the rising need for ultra-low latency, huge connection, and ever-increasing data rates as the globe advances towards the creation of 6G communication networks. In light of this, the authors of this study suggest using deep learning to improve 6G wireless channel state estimates. The input data is effectively encoded by a source encoder in the communication chain, and then redundancy is introduced for error correction by a channel encoder. In order to make the encoded data acceptable for transmission across the communication channel, it is passed into a symbol mapper. This work's novel part is a channel estimator that is based on DL. Two essential steps comprise the channel estimator: acquiring channel data and learning from data. In order to feed the data-driven learning phase that follows, the acquisition stage collects channel data in real-time. The system optimizes the estimating process by learning the complex properties of the communication channel using DL approaches, which allow it to adapt to dynamic alterations. To improve the overall performance and reliability of the communication system, the predicted channel output is revised using the DL-based channel estimator. The suggested method is well-suited for practical communication situations since it improves channel estimate accuracy and shows flexibility to new channel circumstances. A program called MATLAB is used to carry out this job.

## 1.INTRODUCTION

Rapid development in wireless communication technologies has occurred in the last few decades. 5G is a mobile communication standard that allows for the "Internet of Everything" because to its low-latency, large-connectivity, and high-speed capabilities. Some of its most common uses are uRLLC, improved mobile broadband, and massive machine-type communications (mMTC). An astounding 152,200 Internet of Things (IoT) devices will be deployed per minute by 2025, according to projections from the International Data Corporation (IDC). There will be a total of 73.1 zB of data produced by all of the Internet of Things devices in the world. As the number of wireless devices continues to skyrocket, 5G will face formidable obstacles in keeping up with the soaring volume of mobile data traffic and the wide variety of services that users expect. This is why studies focusing on future-proof sixth-generation (6G) technology are already in the works. By all accounts, 6G will outperform 5G in critical areas including security, transmission rate, throughput, energy efficiency, and spectrum efficiency. The channel is intricate and ever-changing in systems that use wireless communication. Communication system performance may be negatively impacted when signals are attenuated or distorted as a result of phenomena such as the multipath effect, the Doppler effect, shadow fading, etc. Channel state information (CSI) is crucial for the correctness of both sent and received signals, and channel estimation aims to estimate CSI at the receiver. By accurately estimating the channel, one may compensate for the received signal's amplitude and phase, allowing for exact data recovery during demodulation at the receiver. This is why physical-layer wireless communication relies heavily on channel estimate. The quality of communication networks can be greatly improved, 5G's performance constraints can be overcome, and 6G's "Intelligent Interconnection of Everything" aim can be achieved by boosting its performance.

## 2.LITERATURE SURVEY

**Bhekisizwe Mthethwa *et al* [2020]** To enhance wireless connection dependability while maintaining spectral efficiency, the suggested uncoded space-time labeling diversity applies labeling variety to a space-time block-coded system. When compared to the conventional alaboudi scheme, USTLD's connection dependability is much greater. In order to estimate the channel, channel statistics and/or sent pilot symbols are needed, in addition to the receiver noise variance, by the channel estimating algorithms. With the goal of reducing the system's bandwidth consumption during blind channel estimation, a neural network machine learning channel estimator that shares transmit power is being developed. The research revealed that the design was highly dependent on the MIMO receive antenna setup. In cases when the validation MSE values are very near to one another, the fitness values have a large disparity to prevent the calculation of equal selection probability. Another thing to note is that the power fraction can't go up to one in a linear fashion, since it would have a detrimental impact on the BER performance of the sent information symbols when their transmit power becomes so small. This implies that knowing the noise variance and second-order statistics of the wireless channel are not necessary.

**Hamza Djelouat *et al* [2021]** In order to improve energy efficiency, presented a grant-free random access is an essential enabler in communications of a machine-type that minimize signaling overhead and delay. Because mMTC traffic is unpredictable, JUICE was able to resolve the compressive sensing issue. In comparison to the baseline methods, the method's simulation results reveal a considerable improvement in user identification accuracy and channel estimation performance, all while reducing signaling cost. Massive connection cannot be supported by grant-based random access methods. It makes it possible to solve a subproblem of the optimization process in closed form. This method delivers baseline MMV JUICE performance with less signaling overhead. With grant-free access, the signaling overhead is lower, and the energy efficiency of the IoT devices is better, than with traditional random access. An effective and relatively straightforward framework for solving optimization problems with several dimensions. When trying to determine which users are really active, the covariance data is invaluable. In contrast to channel realizations, channel spatial correlation changes at a slower rate, and in reality, the channel covariance matrices for all IoT devices are calculated with great precision.

**Sai Huang *et al* [2021]** proven that, particularly in vehicle-to-everything situations, robust channel estimate in time-varying channels is used to ensure the quality of communication services. Using multi-input, multi-output radar to aid in millimeter wave channel estimate improves channel estimation accuracy while reducing pilot overhead. The creation of a channel gain estimator based on DL is done in the gain estimation step. The residual denoising autoencoder is a combination of an autoencoder and a residual structure that is used to remove noise from wireless signals. The resulting signal is then fed into the least squares estimation module in order to get gains. To accomplish high-gain directional beam creation, massive MIMO is necessary because of its poor penetration and high attenuation. The assumption of high hardware complexity allows digital precoding to achieve multiple channel broadcasts for numerous users. A very sophisticated ultra-high-resolution estimate technique.... Capable of handling time-varying channels with great mobility and boasts improved estimate accuracy. The technique successfully calculated the time-varying mmWave channels while cars are traveling at high speeds.

**Junfeng Wang *et al* [2020]** developed a system for wireless communication, the Rice factor ratio is an important metric for gauging the channel's performance (since it shows how bad the small-scale fading is) and for using as a priori data for estimating other metrics, like frequency. As a result, its estimate is crucial for many wireless application cases. This gets rid of the impact of a few superfluous factors, such noise variance, maximum Doppler shift, indistinguishable multipaths, and simply Doppler shift. The Rician frequency selective fast fading channels are then equipped with an expression for the RFR estimate that is both practical and based on flexible mathematical calculations. With an increase in the assisted data length, the analyzed system shows a minor improvement in estimate performance and is resilient to signal-to-noise ratio over and frequency offset. Which are usually faced in wireless communication systems, particularly for high rate wireless communications. Numerous existing wireless communication standards and systems are time-varying and wideband in order to meet the demands of high data rate needs and to facilitate the growth of wireless communications. The channel's multipath components are not included in each bin. Not only does the studied method cut down on algorithm complexity, but it also eliminates the requirement for further parameter estimates and a priori knowledge of the maximum Doppler shift or the Doppler shift, thereby preventing error propagation.

**Qiang Hu *et al* [2021]** deep learning has shown to be a powerful approach for estimating channels in wireless communication systems, particularly in suboptimal situations. Despite this remarkable achievement, DL approaches are still largely unexplored due to a lack of understanding about their inner workings and a general perception that they are black boxes. Since a piecewise linear function is theoretically identical to a deep neural network with a rectified linear unit activation function, the corresponding DL estimator efficiently uses piecewise linearity to achieve universal approximation to a broad family of functions. It does not need any previous knowledge of channel statistics to estimate the least mean-squared error in different circumstances

using the signal model and asymptotically. Statistically, the training data does not correspond to the actual deployment settings. For inputs that are limited to areas with non-empty training samples, valid channel estimates will behave arbitrarily outside of these regions, as mentioned in Remark. Such a likelihood cannot be disregarded and the restriction on the effective input range will cause major problems if the training data statistics do not correspond to the actual channels. Due to their linear nature, the LS and LMMSE estimators exhibit drastically diminished performance when used to nonlinear models. If we want to know when to use DL embedded communication systems, we need to know that DL approaches are only applicable to wireless communication systems.

**Zhao Yi et al [2020]** millimeter-wave massive MIMO has been considered as a promising technology for next-gen vehicle cellular networks in wireless communications due to its capacity to provide very rapid and high-rate data transmission. Beam shaping methods are continuously used in different mmWave systems to provide enough channel gains to mitigate the negative effects of large route losses. To first estimate all route parameters, the iterative cancellation approach is used. Next, establish a judgment threshold to ascertain the genuineness of the predicted routes; this will further enhance the estimate accuracy. With the help of the predicted channel parameters, the channel matrix is rebuilt. Using an analog-only beam shaping method reduces system performance and places various technical limitations. Due to the lengthy training process required by the multiple transmit/receive antennas and the limitations of analog beam formers, the traditional channel estimate techniques are not practical. The algorithm not only predicts the most energetic pathways, but it also predicts additional paths from channels where noise is a major issue. As far as the authors are aware, there has not been research into a high-precision channel estimation algorithm for use in mmWave massive MIMO vehicle systems, particularly in cases where noise interference is significant, and current schemes are unable to adapt the training sequence length to changes in the channel. In a high-speed situation, the channel's state changes rapidly over time, causing the iterative cancellation method's estimate accuracy to decline.

**Ying GAO et al [2023]** designed a map of the radio environment that shows the coverage of the main wireless communication terminals in great detail. An accurate geographical assessment of the channel's state is highly dependent on the surrounding radio frequency spectrum. To prevent harmful affects and get an accurate picture of the channel circumstances, it adds a few of trust nodes. In reality, running and maintaining large-scale sensor networks is costly and challenging, and REM building mistakes are substantial due to a lack of environmental data. It is difficult to prevent some egotistical users from attempting to monopolize spectrum resources or disrupt the primary user's communication when the applicable technology is used in real-world applications, like gathering data from various mobile phones, and it is also impossible to guarantee that all users will be completely honest. In order to get a better REM, the first two approaches use the average power of the mesh as their output. Instead of calculating the average power of each mesh, use the raw data from the normal terminals to conduct interpolation. Although this tactic was thought to be as accurate as any system could be, the database still doesn't know which terminals are really malevolent. While collaborating, intentionally send the database erroneous sensor data. The trust nodes assisted phase decides that the database store less data for the respective purpose, in blue, and the accuracy of collaborative detection has been significantly lowered as a consequence of these CSS assaults.

**Nahid Parvareh et al [2023]** given the opportunity to address the shortcomings of ground-based base stations, unscrewed aerial vehicle-mounted base stations, also known as drone base stations, are seen as having strong future prospects. Take use of the fact that they are very movable, so they can easily relocate if the demand profile changes quickly. Optimizing the 3D positioning of UAV-BSs in real time is essential for making the most of their mobility and, by extension, the network's performance. In comparison to Q-learning, deep Q-learning, and traditional methods, the model's simulation results show a considerable improvement in the network's performance. A problem with non-deterministic solutions that is NP-hard. In most cases, the agent can only choose one possible action at a time from a finite set of options known as a discrete action space. By the time it reaches the testing phase, the agent has absorbed all of the physical cues and user movement patterns. In order to significantly decrease the service latency experienced by the endpoints, UAV-BSs continually fly towards areas with increased user density and demand. As a supplement to cellular connections, they present a number of critical issues that need fixing for a UAV-assisted cellular network to perform well.

**Liqiang wang et al [2021]** proposed A hybrid 6G indoor network design with an ultradense deployment of VLC access points poses significant obstacles to user mobility, however visible light communication is seen as a crucial supplementary technology for exceptionally high sixth generation data transfer. In order to solve these obstacles, an adaptive handover mechanism has been developed. This mechanism employs a deep reinforcement learning optimization algorithm for selection and a smooth handover protocol. Despite VLC's many benefits, there are still a lot of unanswered questions. In a large-scale interior environment with an ultradense deployment of VLC APs, the performance of the RL algorithms used in the previous research is drastically diminished due to the limits on the Q-table. The issue is that the algorithm's learning effectiveness is reduced due to negative feedback produced by remote and worthless encounters. Real-

life learning does not depend on pre-existing data set samples. In this hybrid design, will not remain in range of a single access point for long and will have to move between them often to maintain connection.

**Khaled M. Naguib *et al* [2023]** The transmission of virtual reality data efficiently over 6G cellular networks is no easy feat, requiring both high throughput and very dependable, low-latency connectivity. With the proposed method, End-to-End management is accomplished. It concerns virtual reality users who employ supervised and unsupervised deep learning for centralized resource management. While UDL is the way to go when latency isn't a big issue, our study improves RBs allocation and makes sure that network resources are used effectively to satisfy end-to-end connectivity needs. Having a labeled dataset is necessary for SDL training, although this isn't always the case in network applications. As the time threshold for the connection grows, SDL and UDL converge, meeting the performance and latency requirements of almost all virtual reality users. This is reflected in the overall satisfaction ratio of users. The network's capacity grows, SDL's relative performance advantage over UDL declines, and the two models provide comparable results. This technology has the potential to completely transform the way virtual worlds and VR are used.

**Burak Ozpoyraz *et al* [2022]** Deep learning's remarkable performance in several domains, including computer vision, natural language processing, and voice recognition, may be attributed to its powerful representational capabilities and computational simplicity. New applications and use cases have been developing with severe criteria for next-generation wireless communications as we move ahead to a fully intelligent society with 6G wireless networks. In order to establish the groundwork for exciting 6G applications, this article primarily aims to reveal the latest state-of-the-art developments in the area of DL-based physical layer approaches. Particular emphasis was placed on four encouraging physical layer ideas that are predicted to rule the roost of next-generation communications, including massively parallel input/output systems. The time frequency grid of OFDM permits the versatile use of resource components, which is particularly useful in light of the literature's scant treatment of, and need for, the programming and implementation stages of DL ideas. The limitless degree of mobility makes it impossible to define the system parameters as constants. Large networks requiring authentication of several nodes may be handled via DL-based approaches described in the literature. There is a lot of raw thinking in the current literature since it is so young. They may be used to a wide range of DL networks and system models. A potential issue with these systems is that they presuppose the existence of initial CSI. Applying DL-based solutions to MC waveforms still has several unresolved challenges. The DL literature around these technologies is in its early stages of development; incorporating them into our 6G architecture is a potential next step.

**Martin H. Nielsen *et al* [2022]** anticipated to emerge as a leading provider of wireless connectivity in the near future are satellites placed in low Earth orbit. 5G and 6G networks must be deployed in satellite communication for this to come to fruition. Along with this issue comes the need for transmissions that are efficient with electricity. The first stage of a two-stage training technique uses an AWGN channel and a fixed non-linear front end to train the model. Step two drastically cuts down on training time by adapting to flat fading channels using transfer learning and tweaking the front end model to account for various front ends. There were no more accurate channels or outcomes for the model's ability to correct for variations in amplifiers, steering angles, and power levels without retraining. The transmitter has to be pushed non-linearly to maintain efficiency. The generality is excellent for the same AiP. It is feasible to adjust for variations in both output power and steering angle at the bit prediction side, allowing for decent BER to be maintained even when the signal has severe distortion. There is no geometric guarantee that the distance to the base station will remain constant. Because the non-linearity and noise were not completely removed, the tiny variances occurred. Allows us to preserve the current design of our transmitter. For the most part, satellite transmitters already include band-pass filtering before sending the signal to the antenna in order to comply with the International Telecommunication Union's interference restrictions, thus this isn't a problem.

**Faris B. Mismar *et al* [2023]** detailed the process of enabling handoffs between beams that belong to the same or separate BSs by using deep learning and time series data produced from user equipment beam measurements and locations gathered by the base station. To investigate the efficacy of the proactive beam handoff prediction, three distinct methods using long short-term memory recurrent neural networks were used, along with varying the amount of beam measurement look-backs. The transmitter has to be pushed non-linearly to maintain efficiency. There were no more accurate channels or outcomes for the model's ability to correct for variations in amplifiers, steering angles, and power levels without retraining. This two-stage training method improves data efficiency by reusing the pre-trained receiver for various active phased array models and fading settings. Since several channels were trained using the same starting model, training efficiency was enhanced. This is carried out using validation data, which are samples of data that the deep neural network did not see during training.

**J. C. De Luna Ducoing *et al* [2023]** possible future wireless communication systems' connection and throughput might be greatly enhanced by the suggested multi-user, multi-input, multi-output systems that can accommodate several concurrent streams. The realistic Massively Parallel Non-Linear processing detection method is used to evaluate the reliability, complexity, and resilience of four well-known model-based DL

algorithms that are based on diverse working principles. Even before we get into the training phase, they show less dependability and more complexity than MPNL. High complexity, memory costs, and limited flexibility to various channel instances were some of the downsides that researchers discovered with this technique. Because it makes a lot of mistakes when tested on channels that are different from the one it was trained on, it doesn't do well when faced with changing channel statuses. A major increase in complexity is the price you pay for this. They also struggle to adapt to new network circumstances since learning directly from data is so complicated. It takes on some of the difficulties of the EP technique, namely its excessive complexity, and adds even more complexity with the DNN. Unlike with more traditional procedures, DL ones need training, which is a major drawback.

**Adeeb Salh et al [2021]** established a sixth-generation wireless communication network offers a potential method for delivering a data-driven network that assesses and optimizes the end-to-end behavior and large data volumes of a real-time network at a data rate. It allows for very dependable, low-latency communication, improving data transfer up to a data rate of approximately and attaining transmission latency of milliseconds. Distributing massive data and highly engineered artificial neural networks is computationally intensive, which is the technique's fundamental constraint. Boost capacity by expanding coverage and bandwidth. In the realm of brain-computer interfaces, it may open up new possibilities, one of which is the possibility of "using things via our brain. In distant and expansive areas, it becomes much more difficult to maintain. In addition to the mathematical model, the handling of data from previous transmissions is crucial to ensuring high-quality data. High dependability, low latency, and increased rates of huge data are essential for Brain-Computer Interactions, which are both real and necessary. By using AI approaches for medium-access control, we are able to accomplish power control access to the physical channel for all higher layers and network connection operations. Using a new deep-RL algorithm in conjunction with URLLC to support UAVs is crucial to making smart judgments that maximize energy efficiency in wireless communication networks.

**Latif U. Khan et al [2020]** the need for next-generation wireless networks is heightened by the anticipated meteoric rise in popularity of smart services built on the internet of things. Fall short of meeting all application criteria. They spoke on a machine learning architecture for 6G networks that uses quantum computing, as well as current quantum communication techniques and several unanswered research questions. There is no interference from radio frequency waves and a very wide band width with visible light communication. The scalability, dependability, latency, and energy consumption of current blockchain consensus algorithms are all severely lacking. Various applications relying on visible light communication will need the development of new transceivers with low-range capabilities. The majority of the later schemes are quite intricate. A system's capability is diminished as a result of solution methods' excessive complexity. Because of the inherent unpredictability of virtual networks, they provide many essential services. The fronthaul cost issue and vendor animosity are two other major difficulties.

**Suren Sritharan et al [2020]** Recently, several technological developments have resulted from wireless communications. These include ultra-dense networks, software-based networks, distributed antenna arrays, and network virtualization. In order to achieve ultra-low latency, more advanced automation is required. Introduce a general dataset generation approach for common testing in non-stationary environments. Use it to compare alternative learning models to classic optimum resource management systems. In order to prevent service interruptions caused by the learning model's aging. The data distribution is narrow since the non-stationarity factor  $k$  is low; as a result, the DNN model is able to learn the distribution's behavior. Because the data being studied is always changing, models in a non-stationary setting are inevitable. Take a more practical system into account and do away with this assumption in the high-complexity situation. Since the DNN model is equally complex, it will be unable to represent a more complicated issue. Aside from the high computing complexity, the aging effect is another major problem with many wireless applications. The aging effect is caused by supervised learning models' reliance on the training data, and changing the design of the Neural Network won't fix it. Due to the lack of generally accepted optimal settings, it is common practice to tune each model and set of training parameters independently using methods such as ablation studies and experimental tuning to guarantee that the final product meets all performance and latency benchmarks.

**Swarna B. Chetty et al [2022]** The sixth generation of mobile networks is projected to provide applications and services with reduced latency, ultra-reliability, and larger data speeds compared to the fifth generation. This means that the explained universe will continue to grow with these new networks. To tackle these problems, researchers are looking at micro service techniques, which boost deployment flexibility and modularity by breaking services down into smaller, loosely linked components. Decomposition and effective microservice embedding provide a combined challenge that is difficult to understand and address using precise mathematical models. This issue was so intricate that not even the RL model could provide the best answer. Because it is not possible to estimate the depth of the NNs analytically, a systematic experiment is conducted. Predicting the kind of service that will arrive is not possible. With these advantages come additional expenses and limitations. When applied to the embedding challenge of VNF-Forwarding Graphs, this micro service notion increases the complexity of deployment and architecture. More bandwidth and latency are sought for by

the deconstructed micro-functionalities. The method fails to take into account virtual link mapping and the delays it causes because of the repeating practice, making it unsuitable for networks with more users. Concerns about security and the added complexity of operations are just two of the many difficult issues that arise when using the micro services method in real-time.

**Harish Viswanathan *et al* [2020]** The current emphasis in wireless research is moving closer to 6G as the rollout of 5G networks begins. In order to steer that investigation, it is critical to articulate a goal for future communications now. Achieving accurate representations of the physical and biological worlds in digital twins at every spatial and temporal instant is the essence of connectivity, since it allows us to integrate our experiences across the digital, biological, and physical realms. 6G system needs and technology will be shaped by new themes that arise. It may provide the groundwork for the 6G air interface and network, which would open up new opportunities to use data, computation, and energy for enhanced performance. 6G will be necessary for industrial use cases that depend on much more demanding wireless communication standards. While precise interior localization is feasible with ideal satellite visibility, this is often not the case in automated use cases. To promote a 6G design that is optimized for both communication and perception/understanding of the physical world and people's needs, RAN slices can be specialized for specific video optimization micro-services that are included in that slice but aren't needed in other slices. Keeping sub-network privacy and possible anonymity intact will be a problem to address in the 6G network design due to the dynamic behavior of devices entering or departing the sub-network.

**Shereen S. Omar *et al* [2023]** Intelligent Reflecting Surfaces have the ability to greatly improve sixth-generation wireless networks, which allows for the transfer of ultra-data and the exponential growth of network capacity. The above should serve as motivation to maximize the system's data flow, increase its capacity, and decrease the likelihood of outages so that we can give a better user ratio. Because of their adaptability and portability, the land infrastructure is inadequate. The data satisfaction rate ratio is used to find the proportion of connections that meet the data rate. This is based on the utilization of the outage probability and the likelihood of pleasing users or not. Complexity and output delay are both increased as a consequence of the bigger training data set and the increased number of neurons. In order to determine the ideal amount of IRS components for the system, we look at its capacity performance. We find that the algorithm requires the optimum amount of IRS elements, which increases the user satisfaction ratio for this system. The results of the simulation validate the high-dimensional nonconvex problem of raising the total rate of user communication. Because of this, output delay and device complexity are both increased. The additional components have a somewhat significant power consumption. When implemented correctly, links' very high data throughput and quality of service might guarantee reduced latency and reliable data exchange. Due to the high path-loss characteristics of terahertz channels, frequencies are high, resulting in less interference from users. This proves that, compared to the case with a randomly IRS, the algorithm's benefit is better when the IRS is precisely applied.

### 3. METHODOLOGY

#### 3.1 EXISTING WORK

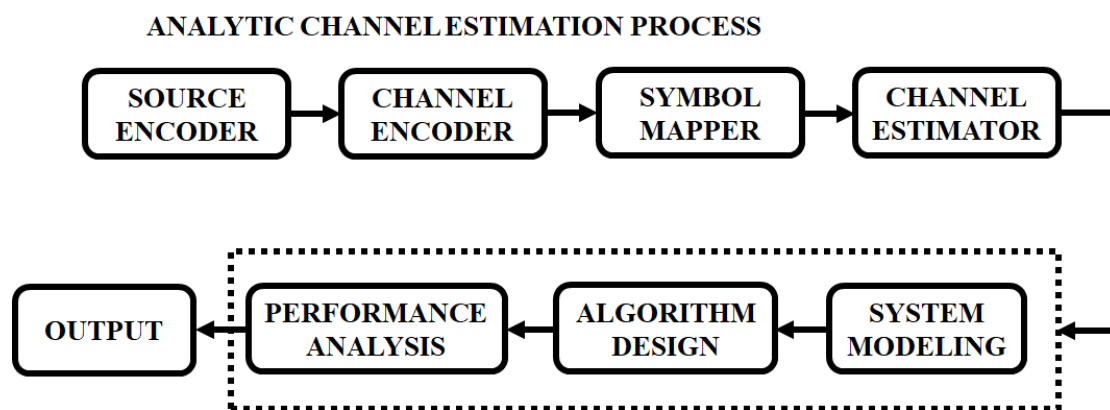

**Figure 1:** Block Diagram of Existing System

Wireless channel estimate and channel status information feedback for 6G are presented by this current system with the use of deep learning. With the proliferation of machine-, vehicle-, and sensor-based automated services and applications, DL is poised to become a popular channel estimate paradigm in the 6G future. Deep learning (DL), a subfield of AI methods, has demonstrated remarkable promise in a number of fields, including picture classification and segmentation, voice recognition, language translation, and others, due to its ability to handle a wide range of frequency bands, wireless resources, and geographical settings. There has been a growing interest in using DL to wireless channel estimate in recent years, thanks to its extraordinary performance. There are a lot of moving parts and subtleties to keep in mind while using the DL approach for channel estimation, which may be daunting due to the inductive nature of DL principles and their difference

from traditional rule-based algorithms. Topics covered will include 6G neural network architecture, DL model selection, training data gathering, and DL-based wireless channel estimate and channel state information (CSI) feedback. In particular, the efficacy of the DL-based wireless channel prediction framework was shown by a combination of numerical studies and many usage. Researchers in the field of communication who are interested in using the DL method for wireless channel estimate will find this study to be an invaluable resource.

### 3.2 DRAWBACKS OF EXISTING SYSTEM

- On the other hand, when dealing with complex wireless settings and systems, the efficiency of this technique decreases.
- Moreover, there is a large overhead caused by the excessive transfer of training data.
- The model mismatch leads to a certain degree of performance deterioration, which is not insignificant.

### 3.3 PROPOSED SYSTEM

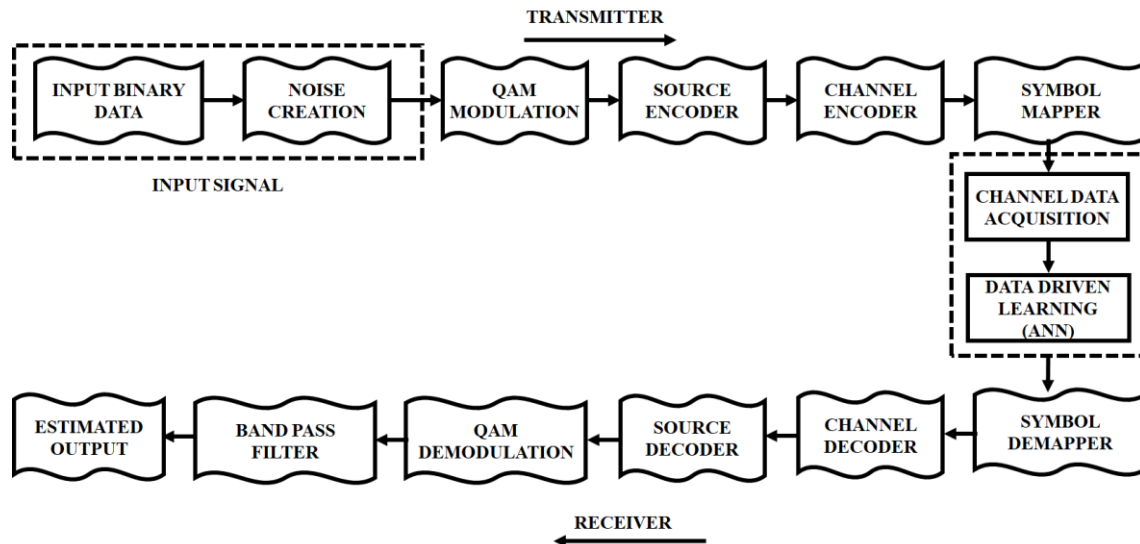

**Figure 2:** Block Diagram of Proposed System

To simulate real-world channel circumstances, the suggested system first processes incoming binary data meticulously and creates controlled noise. Quadrature Amplitude Modulation (QAM) is the next step for the processed signal. In order to facilitate effective transmission, transform the binary data into symbols that represent quadrature amplitude modulation (QAM). To enhance data compression and error correction capabilities, encode the modulated symbols using the source encoder. To make the data more resistant to channel impairments, encrypt it further. Revise the encoded symbols so they may be sent as complex signals. Acquire the sent signal after channel effects and noise by simulating the wireless channel. Learn the properties of the wireless channel using data by using Artificial Neural Networks (ANNs). To get the estimated channel status information, demap the symbols that were received. Reduce channel-induced errors by decoding the received signal with the help of the estimated channel information. Put the original information back together by decoding the data that has been channel-decoded. Return the deciphered symbols to their binary form by demodulating them. If you want better approximated results, use a band pass filter. Collect the predicted output data, which stands for the information that has been rebuilt after the channel estimation and decoding procedures that use deep learning.

### 4.RESULT AND DISCUSSION

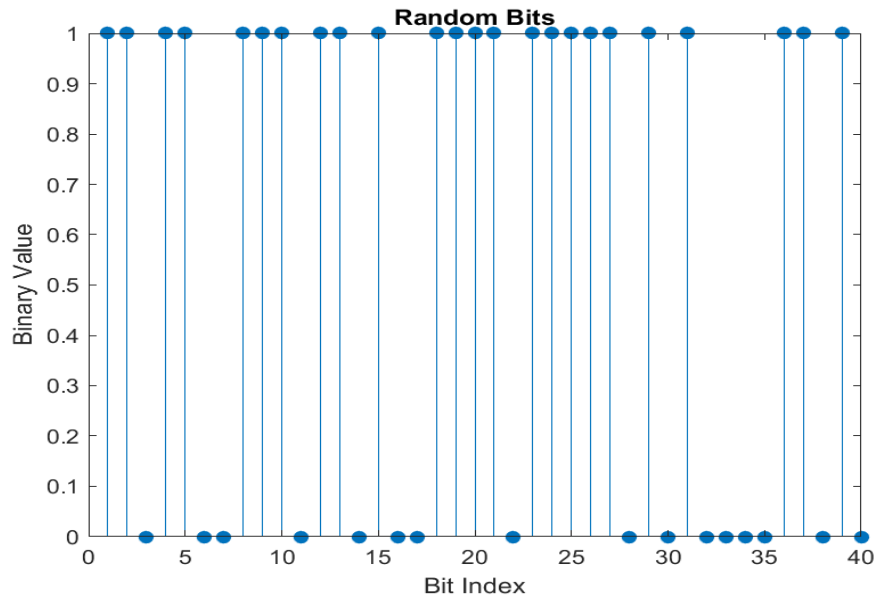

**Figure 3 : Random Bits**

Figure 3 displays random bits. Binary numbers, which can only be either 0 or 1, are described using this notation. To ensure security in the field of cryptography and information theory, it is essential to generate genuinely random bits. Algorithms that simulate randomness using seed values are one source, while physical processes like electrical noise or radioactive decay are another.

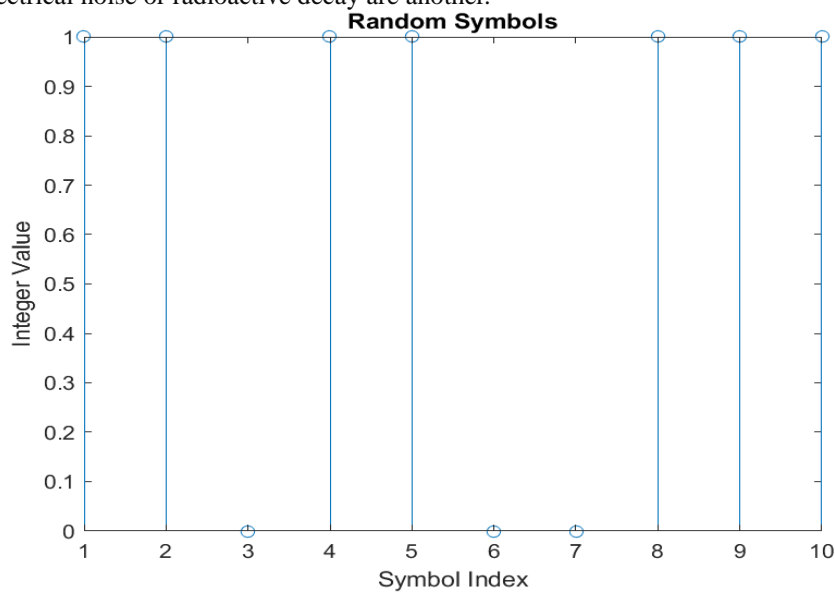

**Figure 4: Random Symbol**

Unpredictable symbols are seen in Figure 4. An expanded variant of a random bit, a random symbol represents a more substantial unit of data. A symbol could represent anything from a number to a letter. It is possible to generate symbols at random by using a mapping technique on a set of randomly generated bits.

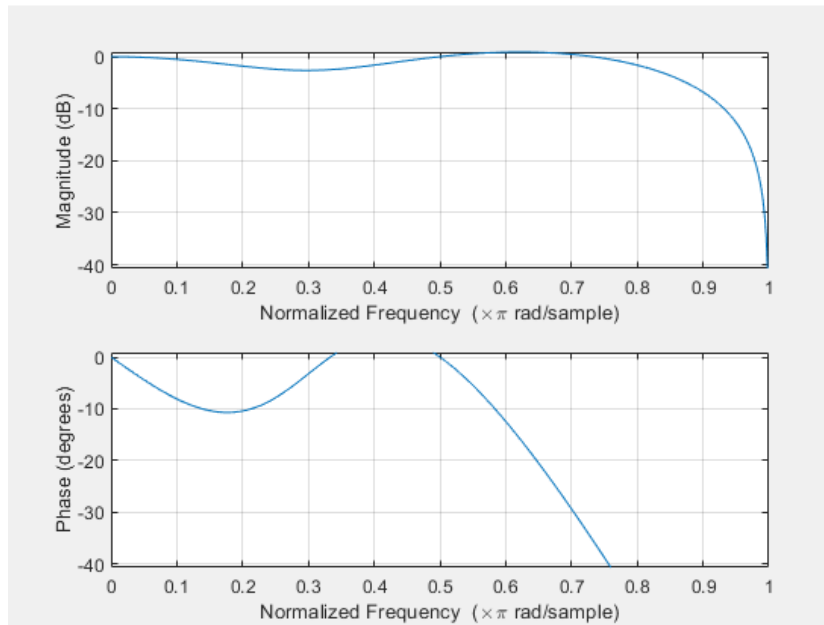

**Figure 5:** Normalized Frequency

As seen in figure 5, this makes the frequency normal. As part of the normalized frequency output procedure, the frequency of various symbols is measured and described. When talking about symbols or random bits, the normalized frequency shows what proportion each symbol has in relation to the overall number of symbols.

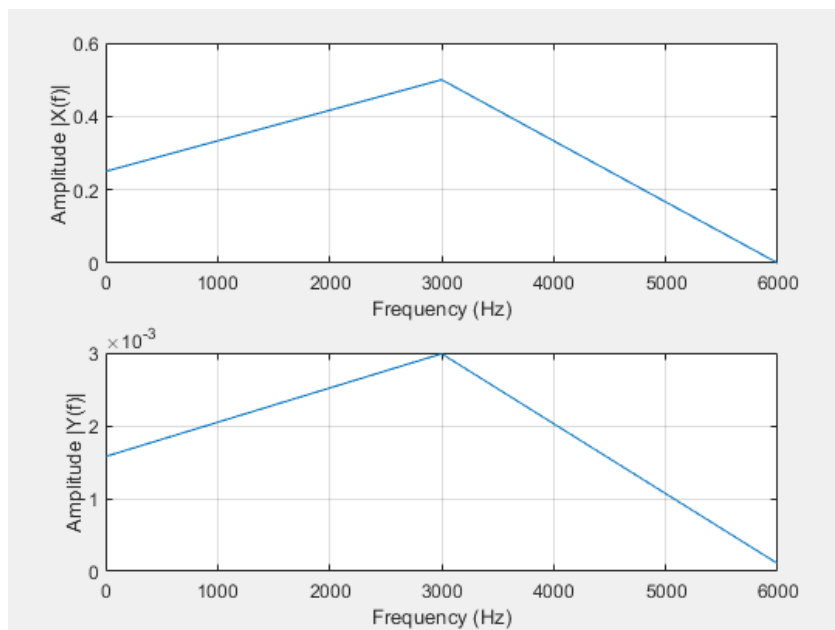

**Figure 6:** Frequency Range

Figure 6 depicts a frequency-modulated signal. The frequency range of a signal or system is the range of frequencies that it can operate over. It specifies the lowest and highest frequencies that may be used for processing, reception, or transmission efficiently. Broadband capacity for data transmission is defined by the frequency range as it pertains to communication networks.

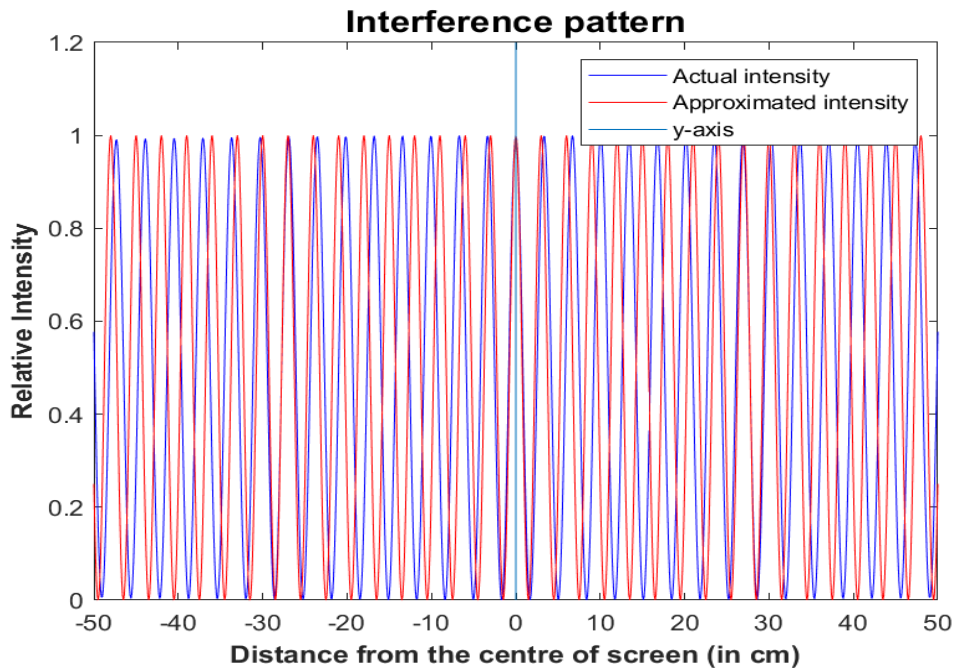

**Figure 7: Interference Pattern**

As seen in figure 7, there is an interference pattern. The pattern of interference is the outcome of constructive or destructive interference, which occurs when many waves superimpose on top of one another. It is characterized by areas of varying intensities. Interference patterns are present in many phenomena, such as multipath interference in radio waves and double-slit interference in optics.

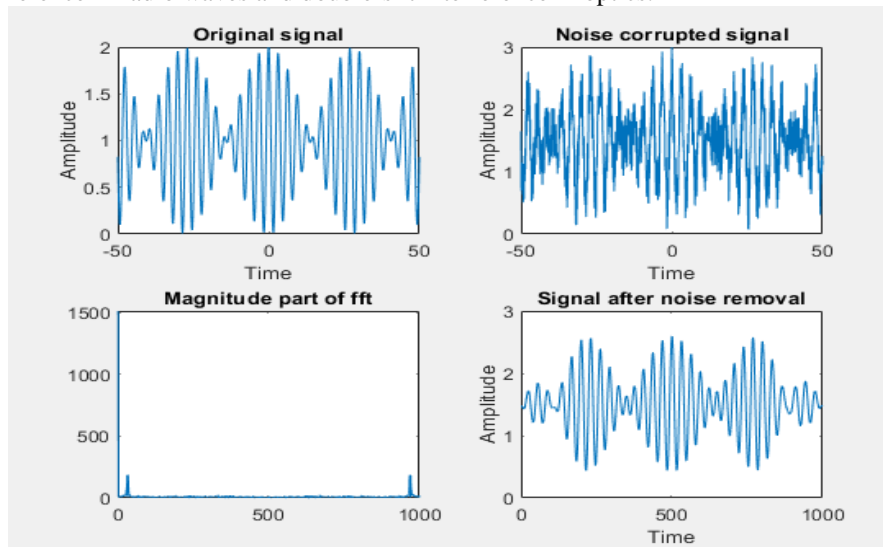

**Figure 8: Noise Signal**

A signal with noise is shown in Figure 8. Noise is any unwanted or unpredictable fluctuation that degrades the quality or accuracy of a transmission. Unwanted random oscillations in a signal are known as noise. Ambient radiation, electrical interference, and changes in temperature are only a few of the many potential sources of noise. The efficiency of communication networks may be affected and the quality of signals can be diminished. It is usually necessary to either analyze or reduce the noise signal since it is undesirable. In order to minimize or remove the noise from the intended signal, the output process employs methods like filtering, signal processing, or statistical analysis. The final product is either a signal with much less noise or statistical metrics that assess how much noise there is.

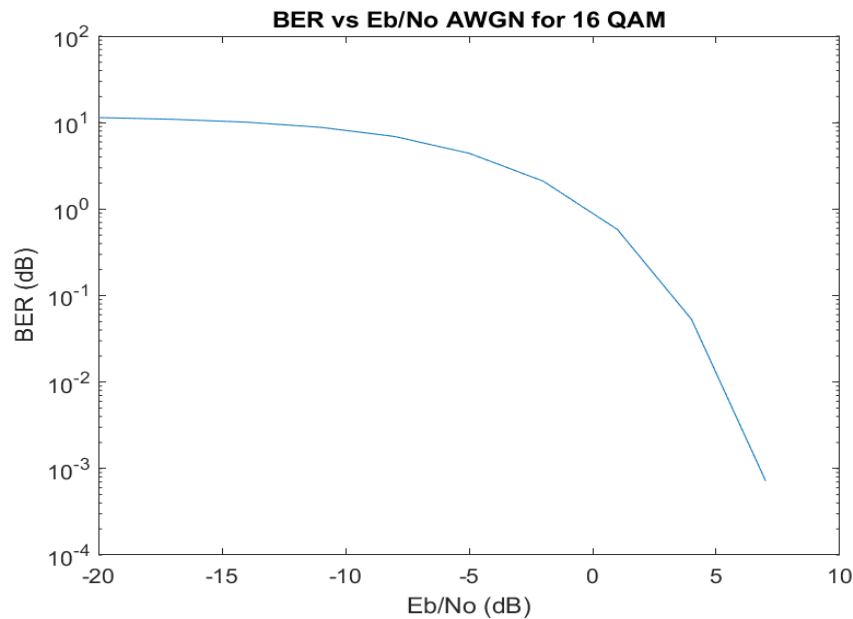

**Figure 9 : BER Value**

In picture 9, we can see a BER value. The bit error rate (BER) is calculated in a communication system by comparing the data that is delivered and received. During the output phase, we add up all the bits that were transmitted and then we look at how many bits were incorrect. You may optimize, debug, or compare the system's performance to specified criteria by looking at the resultant BER value.

### CONCLUSION

This idea was put into action: improved estimate of wireless channel states for 6G connectivity using deep learning. An attractive option for reliably estimating communication channel properties is the DL-based channel estimator that has been suggested. Traditional channel estimate methods have their limits, but with the help of deep learning algorithms, we can adapt to complicated and time-varying channel circumstances. Signal demodulation, equalization, and system dependability are all improved with the incorporation of the DL-based channel estimator, which boosts the performance of communication systems. Wireless communication is one area that might profit from this technology since efficient and resilient communication relies on precise channel estimates. A DL-based channel estimator, symbol mapping, channel encoding, and source encoding are all part of the suggested solution, which provides a holistic view of improving the efficiency of communication systems. The project was carried out using the MATLAB program.

### REFERENCES

1. B. Mthethwa and H. Xu, "Deep Learning-Based Wireless Channel Estimation for MIMO Uncoded Space-Time Labeling Diversity," in *IEEE Access*, vol. 8, pp. 224608-224620, 2020.
2. H. Djelouat, M. Leinonen, L. Ribeiro and M. Juntti, "Joint User Identification and Channel Estimation via Exploiting Spatial Channel Covariance in mMTC," in *IEEE Wireless Communications Letters*, vol. 10, no. 4, pp. 887-891, April 2021.
3. S. Huang, M. Zhang, Y. Gao and Z. Feng, "MIMO Radar Aided mmWave Time-Varying Channel Estimation in MU-MIMO V2X Communications," in *IEEE Transactions on Wireless Communications*, vol. 20, no. 11, pp. 7581-7594, Nov. 2021.
4. J. Wang et al., "Estimation of Rice Factor Ratio for Doubly Selective Fading Channels," in *IEEE Access*, vol. 8, pp. 31330-31340, 2020.
5. Q. Hu, F. Gao, H. Zhang, S. Jin and G. Y. Li, "Deep Learning for Channel Estimation: Interpretation, Performance, and Comparison," in *IEEE Transactions on Wireless Communications*, vol. 20, no. 4, pp. 2398-2412, April 2021.
6. Z. Yi and W. Zou, "A Novel NE-DFT Channel Estimation Scheme for Millimeter-Wave Massive MIMO Vehicular Communications," in *IEEE Access*, vol. 8, pp. 74965-74976, 2020.
7. Y. Gao and T. Fujii, "A Kriging-Based Radio Environment Map Construction and Channel Estimation System in Threatening Environments," in *IEEE Access*, vol. 11, pp. 38136-38148, 2023.
8. N. Parvaresh and B. Kantarci, "A Continuous Actor-Critic Deep Q-Learning-Enabled Deployment of UAV Base Stations: Toward 6G Small Cells in the Skies of Smart Cities," in *IEEE Open Journal of the Communications Society*, vol. 4, pp. 700-712, 2023.

9. L. Wang, D. Han, M. Zhang, D. Wang and Z. Zhang, "Deep Reinforcement Learning-Based Adaptive Handover Mechanism for VLC in a Hybrid 6G Network Architecture," in *IEEE Access*, vol. 9, pp. 87241-87250, 2021.
10. K. M. Naguib, I. I. Ibrahim, M. M. Elmesalawy and A. M. A. Elhaleem, "DL-Based Minimizing Virtual Environment Resource Usage in 6G Cellular Networks," in *IEEE Access*, vol. 11, pp. 118241-118252, 2023.
11. B. Ozpoyraz, A. T. Dogukan, Y. Gevez, U. Altun and E. Basar, "Deep Learning-Aided 6G Wireless Networks: A Comprehensive Survey of Revolutionary PHY Architectures," in *IEEE Open Journal of the Communications Society*, vol. 3, pp. 1749-1809, 2022.
12. M. H. Nielsen, E. De Carvalho and M. Shen, "A Two-Stage Deep Learning Receiver for High Throughput Power Efficient LEO Satellite System With Varied Operation Status," in *IEEE Access*, vol. 10, pp. 60904-60913, 2022.
13. F. B. Mismar, A. Gündoğan, A. Ö. Kaya and O. Chistyakov, "Deep Learning for Multi-User Proactive Beam Handoff: A 6G Application," in *IEEE Access*, vol. 11, pp. 46271-46282, 2023.
14. J. C. De Luna Ducoing, C. Jayawardena and K. Nikitopoulos, "An Assessment of Deep Learning Versus Massively Parallel, Non-Linear Methods for Highly-Efficient MIMO Detection," in *IEEE Access*, vol. 11, pp. 97493-97502, 2023.
15. A. Salh et al., "A Survey on Deep Learning for Ultra-Reliable and Low-Latency Communications Challenges on 6G Wireless Systems," in *IEEE Access*, vol. 9, pp. 55098-55131, 2021.
16. L. U. Khan, I. Yaqoob, M. Imran, Z. Han and C. S. Hong, "6G Wireless Systems: A Vision, Architectural Elements, and Future Directions," in *IEEE Access*, vol. 8, pp. 147029-147044, 2020.
17. S. Sritharan, H. Weligampola and H. Gacanin, "A Study on Deep Learning for Latency Constraint Applications in Beyond 5G Wireless Systems," in *IEEE Access*, vol. 8, pp. 218037-218061, 2020.
18. S. B. Chetty, H. Ahmadi, M. Tornatore and A. Nag, "Dynamic Decomposition of Service Function Chain Using a Deep Reinforcement Learning Approach," in *IEEE Access*, vol. 10, pp. 111254-111271, 2022.
19. H. Viswanathan and P. E. Mogensen, "Communications in the 6G Era," in *IEEE Access*, vol. 8, pp. 57063-57074, 2020.
20. S. S. Omar, A. M. A. El-Haleem, I. I. Ibrahim and A. M. Saleh, "Capacity Enhancement of Flying-IRS Assisted 6G THz Network Using Deep Reinforcement Learning," in *IEEE Access*, vol. 11, pp. 101616-101629, 2023.